

 **Lustrolite[®]**

 **Lustrolite 100[®]**

Installation Guide

Commercial & Residential

Applications

November 2018 edition

Introduction

This guide has been developed for the preparation and installation of Lustrolite for a range of decorative vertical applications in Commercial and Residential situations.

It is imperative that installers carefully read and understand the contents of this guide thoroughly before commencing installation.

Failure to follow the procedures in this guide may affect performance and warranty.

Although this guide applies to a range of installation situations, it may not cover your specific application. If you are uncertain with any aspect of installation, please contact your local distributor or EGR Building Products Representative listed below.

For simplicity, this guide refers to Lustrolite only, which can mean Lustrolite or Lustrolite 100.

EGR Building Products Representatives

National

Lindon Flancbaum
909 744 4977
lflancba@egrusa.com

East Coast & Canada

Juan Rubio
909 732 0313
jrubio@egrusa.com

Mid West

Jeffrey Johnson
909 815 0431
jejohnso@egrusa.com

Table of Contents

Preliminaries	p1	Specific Applications	p17
Personal Protective Equipment	p1	Commercial & Residential Walls.....	p17
Recommended Tools	p1	Restroom Doors & Partitions	p18
Optional Tools	p1	Standoff Features & Signage	p19
Installation Materials	p2	Cabinet Doors.....	p21
Important Considerations	p2	Shower & Bath Walls	p22
		Backsplashes.....	p24
General Methods	p4		
Step 1 – Sizing & Cutting Lustrolite	p4		
Step 2 – Drilling Lustrolite	p5		
Step 3 – Edge Finishing	p6		
Step 4 – Preparing for Panel Installation	p7		
Step 5 – Completing Lustrolite Installation	p8		
Step 6 – Laminating Lustrolite.....	p10		
Step 7 – Jointing & Capping Lustrolite with Profiles .	p12		
Cleaning & Maintenance	p16		
Warranty	p16		

Personal Protective Equipment

When working with Lustrolite, adequately protect yourself by wearing:

- High visibility work wear
- Hard hat (if applicable)
- Safety glasses
- Safety ear muffs or earplugs
- Nose protection mask, dust mask or respirator
- Safety gloves
- Appropriate covered footwear



Figure 1: Safety Work Wear

Recommended Tools

The following tools are recommended for working and installing Lustrolite panels:

- Tape measure
- Builders pencil, fine felt tip pen or fine marking crayon in a color different to panel color
- Chalk line
- Builders square
- Builders clamps
- Power saw or table saw with sharp fine tooth carbide tipped blade or equivalent
- Jig saw with fine tooth blade
- Electric or cordless drill
- Blunt drill bits ¼", etc
- Hole saws
- Electric planer
- 240 grit long sanding block (12" preferred)
- 120 grit sanding block or pad
- Fine file
- 2" paint brush
- Caulking gun
- 1½" to 2" flexible plastic trowel or putty knife
- Builders work bench
- Saw horses

Optional Tools

- Aluminum cutting tool (if using aluminum profiles for panel jointing and capping)
- CNC router for cutting and drilling Lustrolite
- Orbital sander with 120 grit pad if laminating Lustrolite to wood board

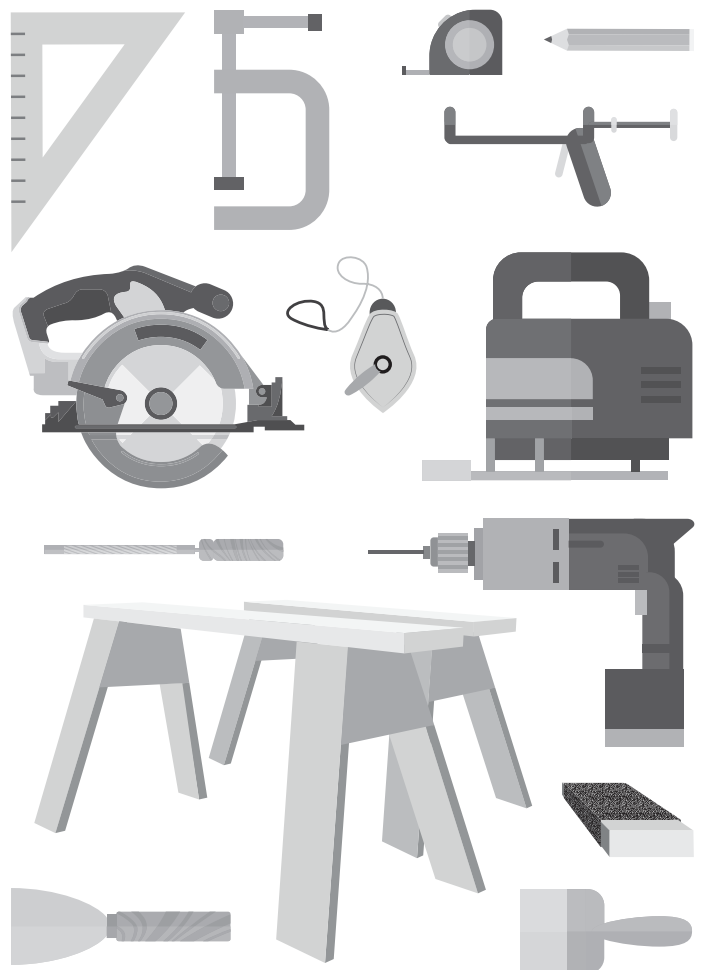

Figure 2: Installation Tools

Installation Materials

The following materials are required to complete Lustrolite installation:

- Sacrificial wood boards such as 1/2" MDF or particleboard
- Satin or low sheen acrylic paint in a color matching Lustrolite being installed
- Masking tape, 3/4" wide or similar
- Clear **neutral cure** wet area silicone sealant
- Double sided polyethylene adhesive tape, 1/2" wide x 1/16" (approximately 1.6mm) thick
- Liquid polyurethane (PUR) adhesive or similar (if laminating)
- Aluminum or PVC profiles such as end caps and internal corner (if applicable)
- Standoff clamps with rubber grommets (if applicable)
- VuPlex Plastic Polish (or equivalent)
- Clean microfiber cloth



Figure 3: Installation Materials

Important Considerations

- **To avoid possible color variation, always ensure the Lustrolite panels used for each project or area of a project are from the same batch. The batch number can be located the panel's peel coat.**

If in doubt, please contact EGR or your local distributor representative.

- Exercise care when lifting Lustrolite as panels are bulky. A two person lift is recommended.
- Lustrolite must be stored indoors out of direct sunlight and extreme heat and cold.
- Lustrolite must be stacked horizontally with adequate support to avoid bowing.
- Where possible minimize dust in the installation area
- Ensure sufficient lighting and adequate power supply exist in the work area
- Ensure adequate ventilation exists in the work area
- Install Lustrolite at or around room temperature; that is between 60 ° F and 85 ° F.
- Lustrolite expands and contracts with temperature changes at the rate of 0.65mm/36"/18° F therefore 5/32" (4mm) expansion gaps must be used at panel joints and junctions with walls, counter tops, floors and other surfaces. *An exception to this is when Lustrolite is PUR*

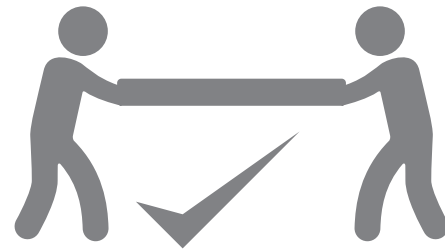

Figure 4: Two Person Carry

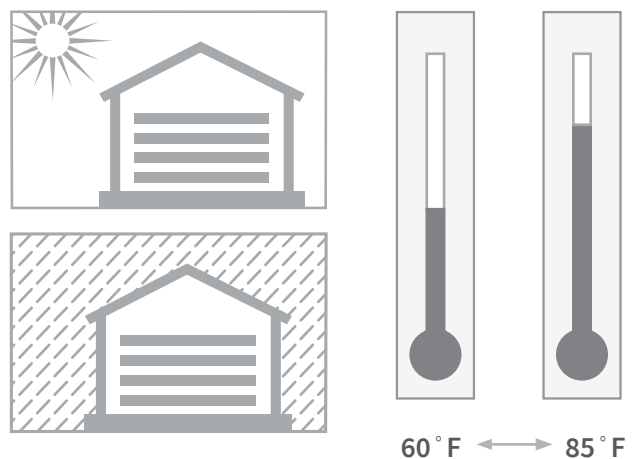

Figure 5: Storage and Installation Conditions

laminated to substrates for door and partition applications, then expansion gaps are not generally required.

- Using a color matching paint to the Lustrolite panel, paint wall behind Lustrolite joints and junctions with horizontal and vertical surfaces such as floors, countertops, other walls and fixtures. *An exception to this is when profiles are used to joint panels or cap edges, then painting is not required.*
- When using silicone and double sided tape to adhere panels to the substrate use tape which is a compatible color with the Lustrolite panel color being installed. For example, use clear or red tape with red panels and white or clear tape with white panels. Use black or gray tape with black panels.

- Tape is used secure Lustrolite in place while silicone cures. Therefore tape can be omitted if adequate pressure is available to press Lustrolite against substrates such as when laminating. If in doubt, use tape.
- Use only clear neutral cure wet area silicone sealant. If the package does not state the silicone is neutral cure, do not use.
- Lustrolite should be installed against a flat supporting surface (e.g. wall lining) and never to framework alone. *An exception to this is when Lustrolite is used in conjunction with standoff clamps, or adhered to an aluminium frame for cabinetry doors.*



Step 1 – Sizing & Cutting Lustrolite

Preliminaries

- Use sharp carbide tip circular saw blades with minimum 60 teeth
- Use sharp fine tooth jig saw blades for cutting aluminum or plastic
- Do not remove peel coats
- If using power saw or jig saw, cut Lustrolite color side up
- If using table saw or CNC router, cut Lustrolite color side down
- Clamp sacrificial wood board underneath Lustrolite when using power saw or jig saw to prevent bowing, vibration and chipping of the clear face side
- Power saw and table saw blades should extend through Lustrolite by no more than 1/2"
- Never create sharp internal corners

Procedure

- Mark cut lines on panels using pencil or chalk line
- Select cutting tool and cut Lustrolite to correct size
- If using a power or jig saw, keep saw moving, do not stop.
- If using a table saw, keep Lustrolite moving through the blade.
- To create a cut out at openings such as doorway or window or at fixtures such as bulkhead or cupboard:

Drill a hole at the corner (See section Drilling Lustrolite for correct procedure for drilling holes in Lustrolite)

Cut from each panel edge into the curve of the hole using applicable saw.

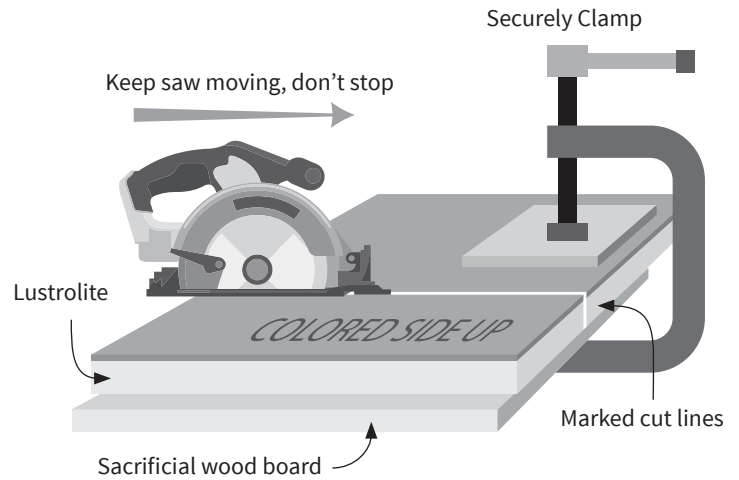

Figure 6: Cutting with Power Saw

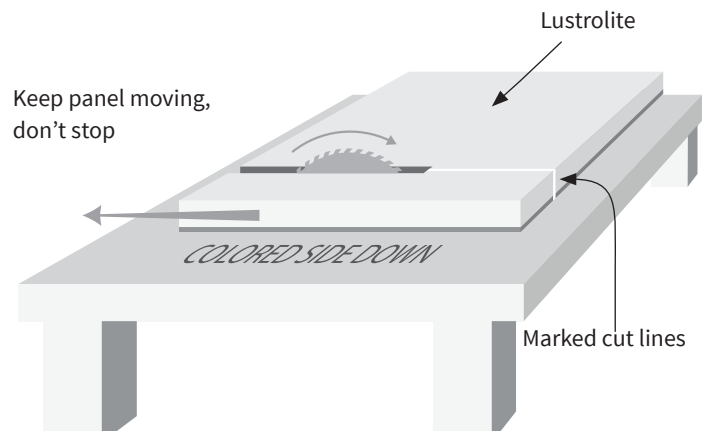

Figure 7: Cutting with Table saw

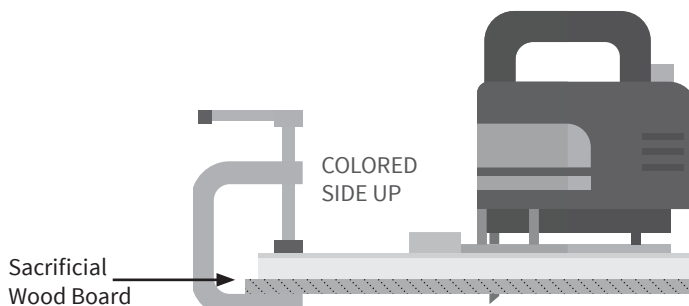

Figure 8: Cutting with Jigsaw

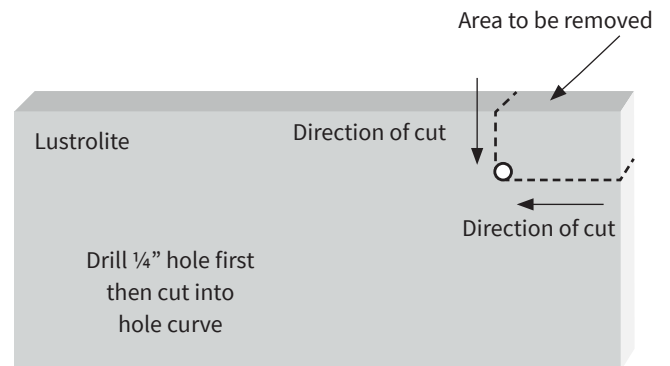

Figure 9: Creating a Cut Out

Step 2 – Drilling Lustrolite

Preliminaries

- Use only blunt drill bits for drilling steel or plastic
- Drill holes at slow to medium speed
- Never insert a fastener (eg. screw or nail) directly into Lustrolite. Fasteners must pass through pre drilled holes in Lustrolite and fix into the substrate
- Do not remove peel coats
- Holes can be drilled prior to or after panels have been installed on a wall or other substrate
- If not yet installed, clamp sacrificial wood board underneath to support Lustrolite when drilling
- Always drill through the clear side of Lustrolite
- Holes up to 1/4" diameter must not be closer than 1/2" to panel edge
- Holes with a diameter larger than 1/4" must be 1" minimum from panel edge
- Holes must be 1/16" (2mm) greater in diameter than fasteners, plumbing and other penetrations to allow for expansion of Lustrolite
- To avoid Lustrolite cracking do not create long penetrations near the panel edge

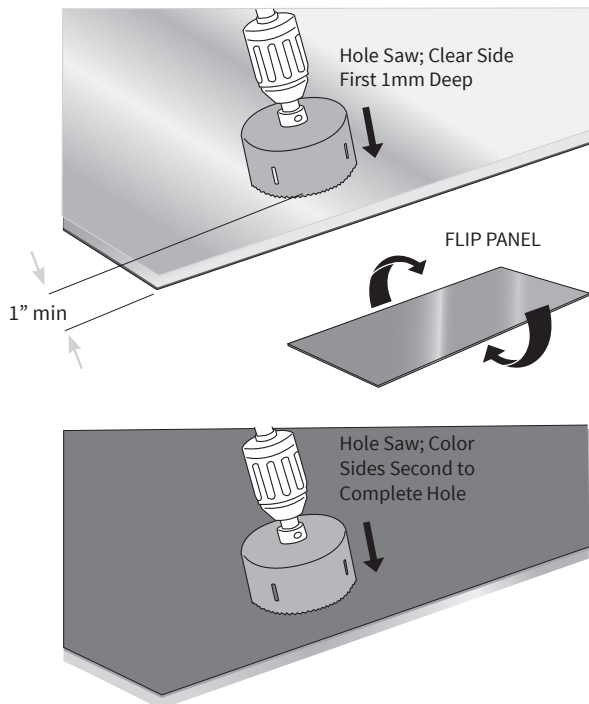

Figure 10: Drilling with Hole Saw

Drilling General Holes

- Mark holes on clear side
- Drill hole through Lustrolite into sacrificial board, wall or substrate
- For holes larger than 1/4", drill pilot holes and work up to the required diameter

Drilling for Power Outlets, Vents & Other Items Requiring Non Circular Holes

- Mark area to be removed on clear side
- Drill hole in each corner of penetration on clear side
- Turn over panel and clamp sacrificial wood board underneath Lustrolite with color side up
- Cut with jig saw from hole curve to hole curve and remove waste material
- Lightly sand penetration edges if burred

Drilling for Door Knob, Plumbing or Other Items Requiring Large Circular Holes

- Mark center point of hole on clear side
- Using hole saw drill 1mm into Lustrolite surface
- Turn over panel and clamp sacrificial wood board underneath Lustrolite with color side up
- Using hole saw drill through color layer and complete penetration
- Lightly sand penetration edges if burred

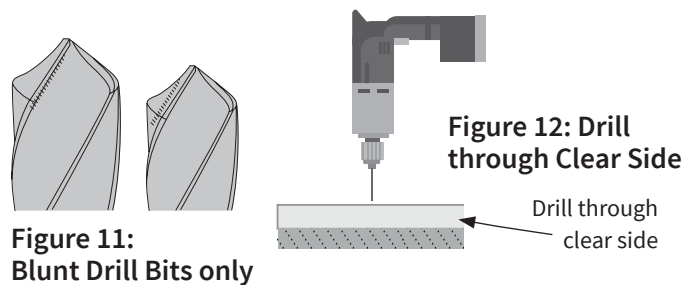

Figure 11: Blunt Drill Bits only

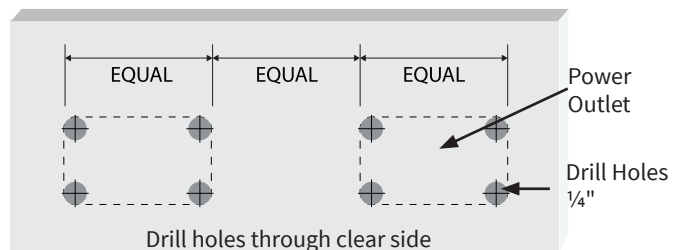

Figure 13: Power Outlets

Step 3 – Edge Finishing

Preliminaries

This procedure relates to exposed visible panel edges (those not terminating at another wall, panel, floor, ceiling or other fixture)

- A number of different exposed edge treatments can be achieved
- The simplest treatments are achieved using an electric planer and sanding block and include square, bevels, miters and simple rounded finishes
- Other more complex edges such as those incorporating curves can be achieved but will require special equipment
- If using electric planer, ensure blade is sharp and well maintained

Creating Simple Square Edge, Bevel, Miter or Pencil Finishes

- Set electric planer to applicable depth
- Plane edge to achieve desired finish. Keep planer moving, do not stop
- Sand edges with 120 grit long sanding block then 240 grit block until desired finish is achieved

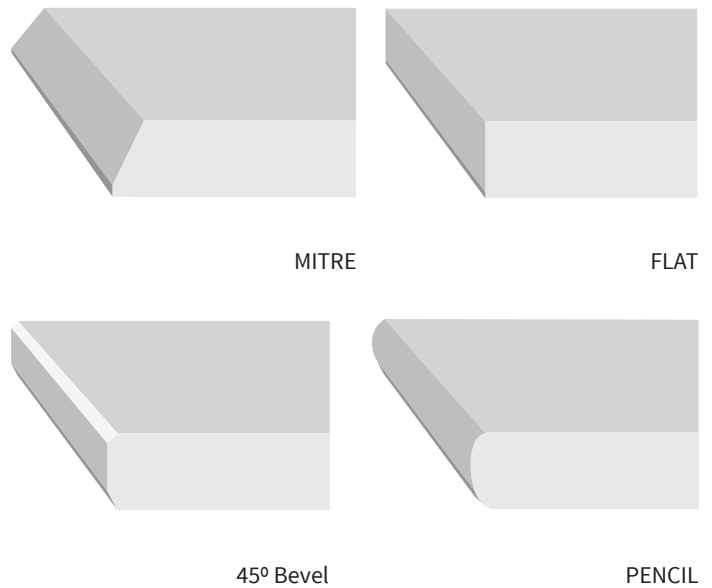

Figure 14: Different Edge Finishes

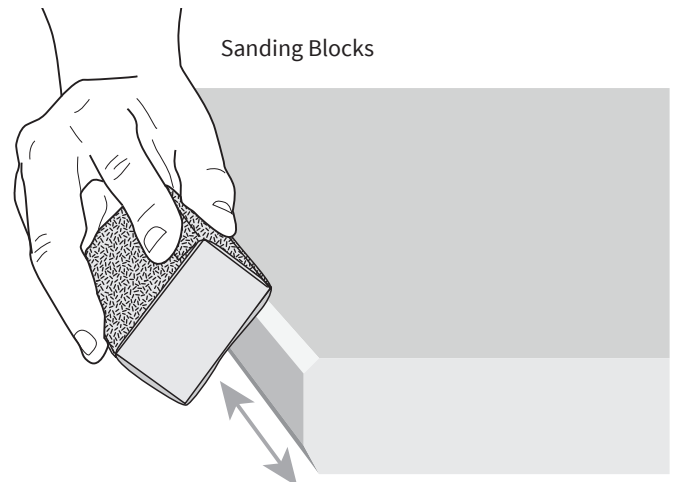
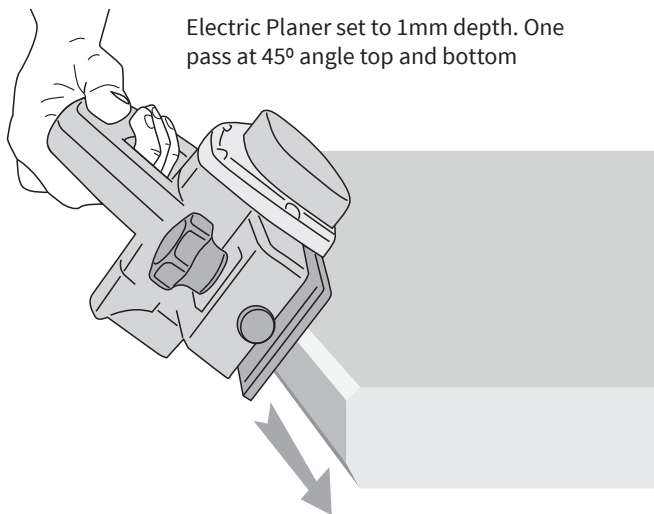

Figure 15: Creating a Bevel Edge

Step 4 – Preparing for Panel Installation

Preliminaries

- Color side is the back side and is installed against the wall or substrate

All Panels or One Panel at a Time

- Remove peel coat on color side of panel
- Using a 120 grit sanding block or scouring pad scuff the entire color layer using a circular motion. **Do not scuff rear of Décor Fusion Lustrolite patterns such as Lavato Oak Titanium or Calacatta Marble**
- Remove all dust and residue from rear panel
- Add strips of double sided tape at approximately 12" centers parallel to the panel length. Do not exceed 12" centers. Tape strips should commence and end approximately 1/2" from panel edges
- Add strips of double sided tape on opposite sides of large circular penetrations and all sides of rectangular penetrations for power outlets, vents and similar. See Figure 19 on page 8.
- Trial fit each panel with tape applied to ensure trim size and expansion gaps are correct. If not take applicable remedial action

Work with One Panel at a Time

- Apply 1/4" silicone bead in wavy motion between tape strips. Increase waviness at panel ends
- Apply silicone beads around penetrations
- Remove tape liner
- Install panel by resting on removable spacers (eg Lustrolite scrap piece) at the bottom and between panels
- Firmly compress panel in all areas to ensure tape bonds and silicone contacts the wall or substrate
- To help create flush panel edges apply strips of masking tape across joints at 18" centres. For areas that require additional pressure, use two pieces of tape diagonally adhered and reduce centers.

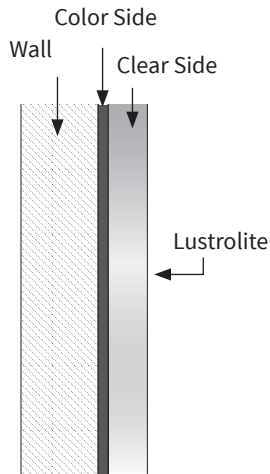
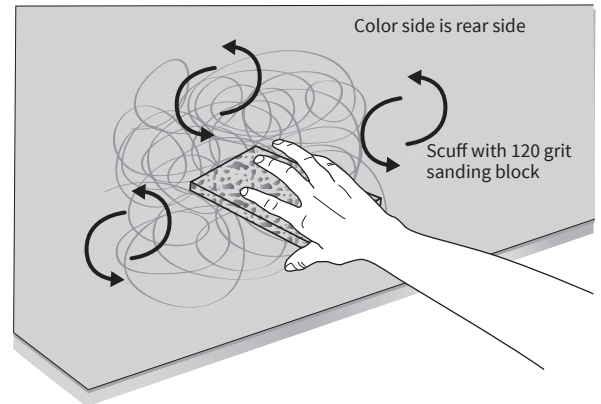

Figure 16:
Color Side to Wall



Do not scuff if installing a Lustrolite Décor Fusion pattern such as Lavato Oak, Titanium or Calacatta Marble

Figure 17: Rear Side Preparation

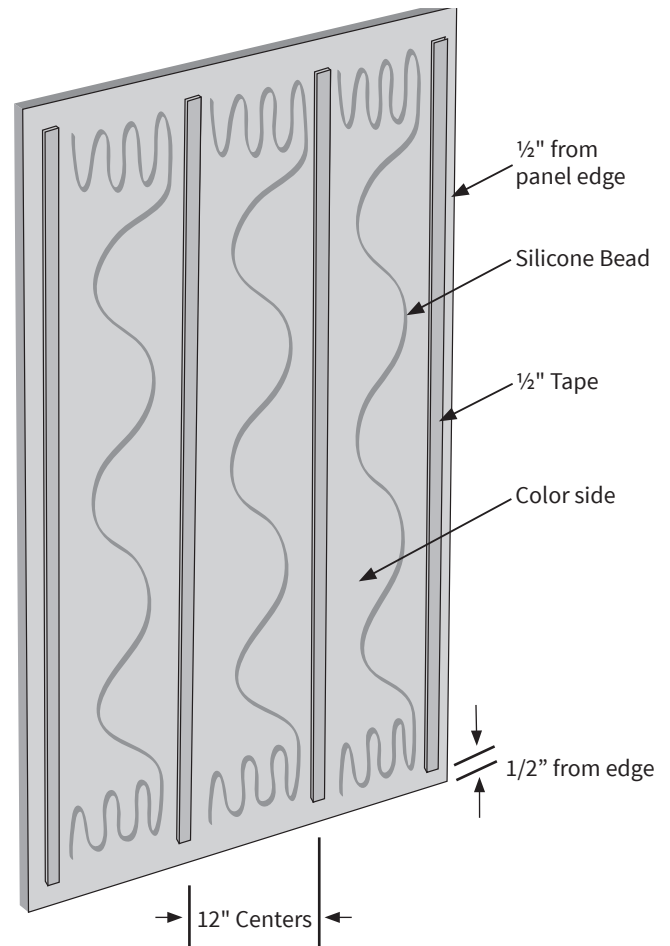

Figure 18: Silicone and Tape Layout

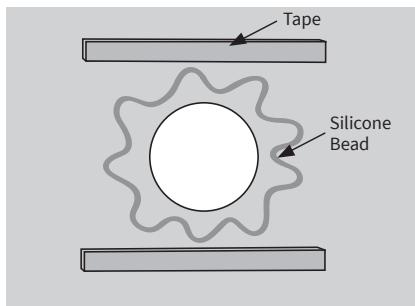

Figure 19: Silicone and Tape at Penetrations

Step 5 – Completing Lustrolite Installation

Preliminaries

After each panel has been installed on the wall or substrate and silicone has cured sufficiently, carefully remove all masking tape, spacers and examine all peel coats.

If peel coats are in good condition and adhered well to the face of each panel follow Step A. If peel coats are peeling away at edges, go to Step B

Step A - Peel Coats in Good Condition

- Seal all joints (and ends) with clear neutral cure wet area silicone.
- Remove excess silicone with plastic trowel to create a flush finish with panel surface
- Carefully remove each peel coat in one smooth continuous action to create a neat and straight finish to the silicone
- Excess silicone can be removed with microfiber cloth dipped in mineral spirits
- When silicone has cured, spray Lustrolite with VuPlex plastic polish or equivalent and wipe with soft, clean microfiber cloth

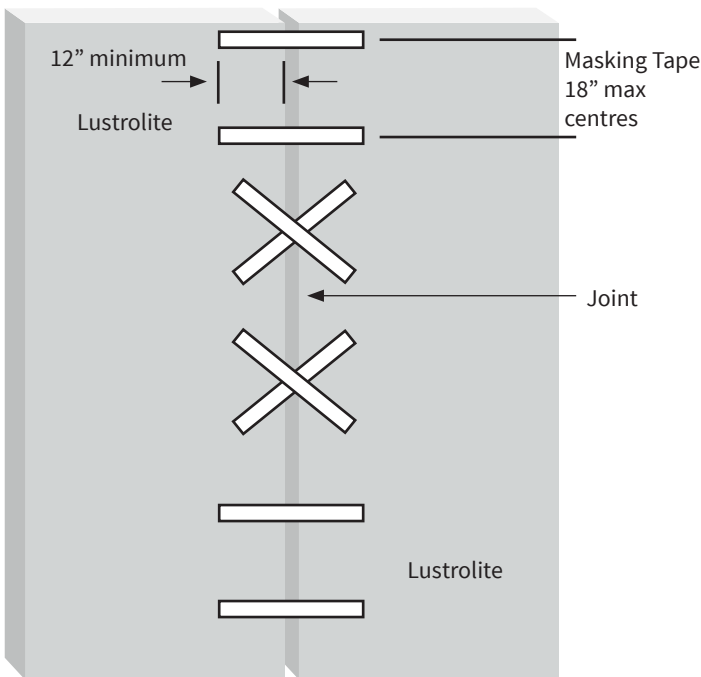

Figure 20: Flush Panel Edges during Installation

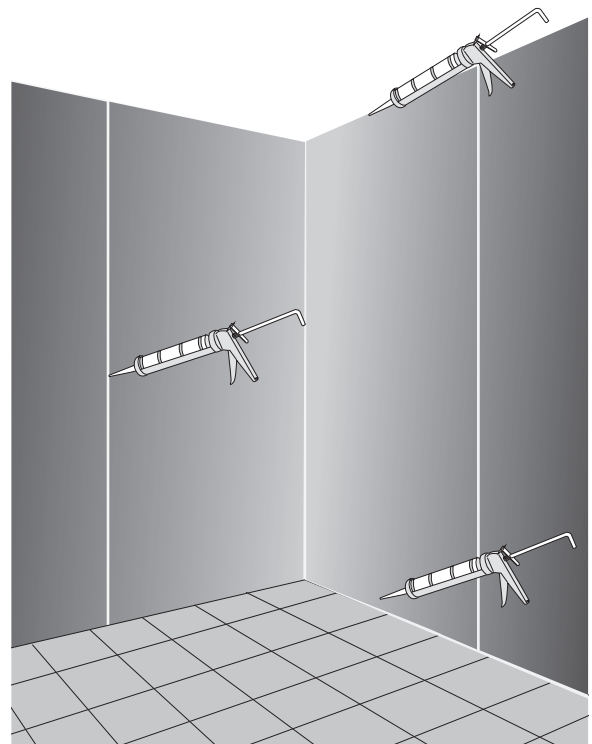

Figure 21a: Sealing Joints

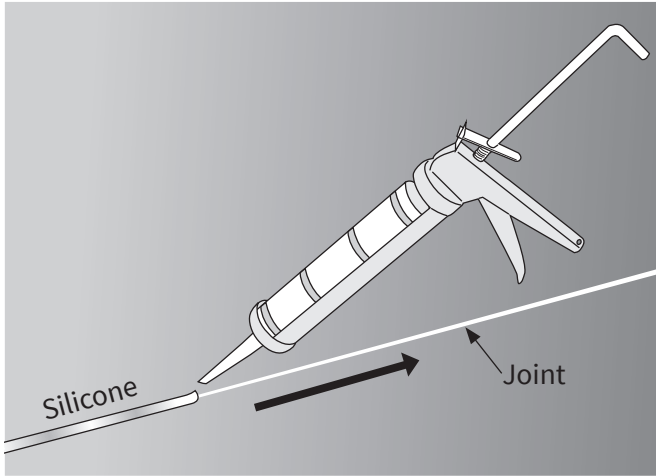

Figure 21b: Sealing Joints

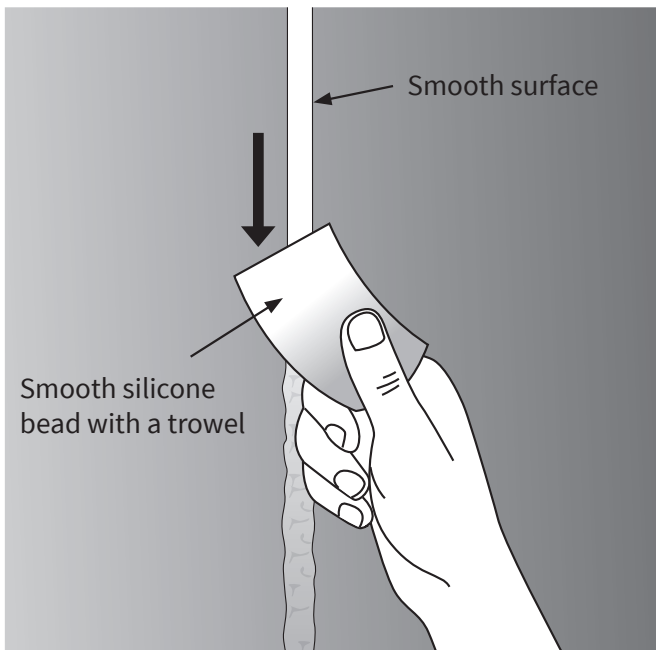

Figure 22: Finishing Silicone at Joints

Allow all silicone beads to cure for 24 hours

Excess silicone can be removed using a soft cloth dipped in mineral spirits or kerosene

Remove peel coat or masking tape immediately after troweling silicone

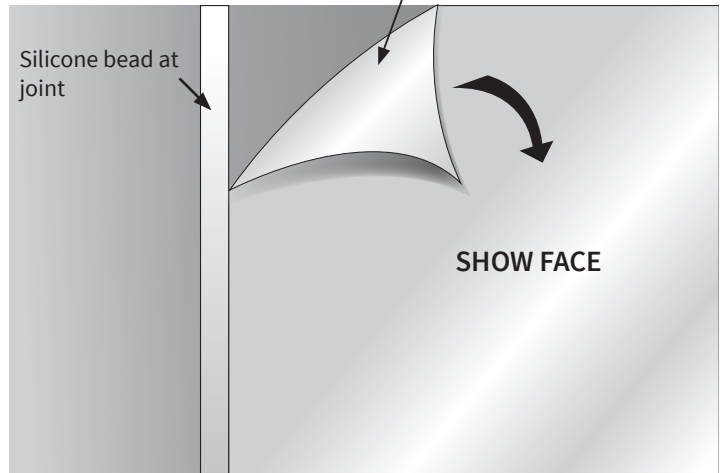

Figure 23: Removing Peel Coat

Step B - Peel Coats Peeling at Edges

- a. Peel back approximately 1½” to 2” of peel coat from edges and carefully apply masking tape either side of joint
- b. Seal the joint (or end) with clear neutral cure wet area silicone
- c. Remove excess silicone with plastic trowel to create a flush finish with panel surface
- d. Carefully remove peel coat then the masking tape in one smooth continuous action to create a neat and straight finish to the silicone
- e. Excess silicone can be removed with microfiber cloth dipped in mineral spirits
- f. When silicone has cured, spray Lustrolite with VuPlex and wipe clean with soft, clean microfiber cloth



VuPlex

Step 6 – Laminating Lustrolite

Preliminaries

Some applications require Lustrolite to be laminated to a wood substrate such as MDF, particleboard or plywood.

Lustrolite can also be laminated back to back to make thicker more stable panels or if identical clear faces are desired.

- Do not remove peel coat on clear side of Lustrolite during these procedures
- Use an applicable laminating adhesive such as Liquid PUR (Polyurethane Reactant) if laminating to wood
- Use clear neutral cure wet area silicone if laminating Lustrolite to Lustrolite
- Laminate in a clean, dry environment where there are no air borne contaminants such as dust and other particulates
- More than one Lustrolite panel can be laminated at a time, however ensure the quantity can be managed. No more than three to four at a time for one or two installers.

If laminating multiple panels, block stack and press

If laminating Lustrolite to wood substrate, see section Laminating Lustrolite to Wood Substrate

If laminating Lustrolite back to back, see section Laminating Lustrolite to Lustrolite.

Note that liquid PUR has a high propensity to foam especially around high moisture / humidity. Take care to ensure the actual PUR glue, not the foam only, contacts Lustrolite.

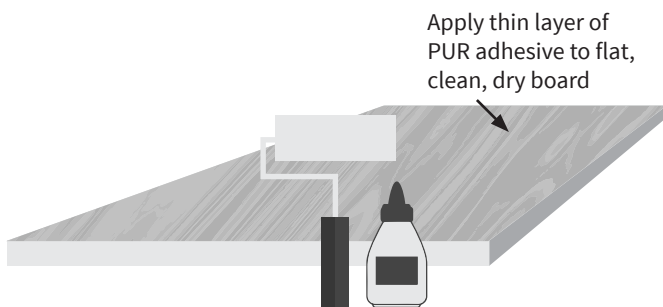

Figure 24: Wood Substrate Preparation

Laminating Lustrolite to Wood Substrate

- Cut Lustrolite to size (See section Sizing & Cutting Lustrolite for correct procedure). Clean away all residues and ensure surface is dry.
- Cut wood board to size. Finish with 120 grit sanding block or orbital sander if required. Ensure surface is smooth and dry and clean away all residue.
- Carefully apply a thin layer of PUR adhesive to the entire surface of wood substrate only using notched trowel, paint brush or roller.
- Remove color side peel coat of Lustrolite if it exists
- Laminate Lustrolite to the wood board. Apply even pressure across the face of Lustrolite so it adheres well. One method is to clamp another wood board to the face of Lustrolite so it is sandwiched between the wood boards.
- If laminating multiple panels, block stack and press.
- Allow PUR adhesive to cure as per manufacturer's instructions.
- Leave clear side peel coats in place until installation of the laminated Lustrolite panel is complete.

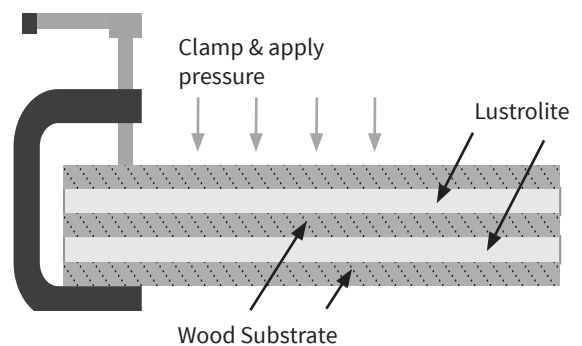

Figure 25: Laminating Lustrolite Wood Substrate; Block Stack & Press

Laminating Lustrolite to Lustrolite

- a. Cut Lustrolite to size (See section Sizing & Cutting Lustrolite for correct procedure). Clean away all residue and ensure surfaces are dry.
- b. Remove color side peel coats if they exist and scuff color sides of both panels with 120 grit sanding pad. **Do not scuff rear of Décor Fusion Lustrolite patterns such as Lavato Oak, Titanium or Calacatta Marble**
- c. Ensure surfaces are clean and dry, then carefully apply a ¼” bead of neutral cure wet area silicone in a wavy motion to the color side of one panel only.
- d. Bring the two color surfaces together.
- e. Apply firm and even pressure across the faces of both Lustrolite panels so they adhere well. One method is to sandwich Lustrolite between wood boards and clamp.
- f. If laminating multiple panels, block stack and press.
- g. Remove excess silicone with plastic trowel and cloth dipped in mineral spirits or kerosene.
- h. Allow silicone to cure for 24 hours or as per manufacturer’s instructions.
- i. Leave clear side peel coats in place until installation of the laminated Lustrolite panels is complete.

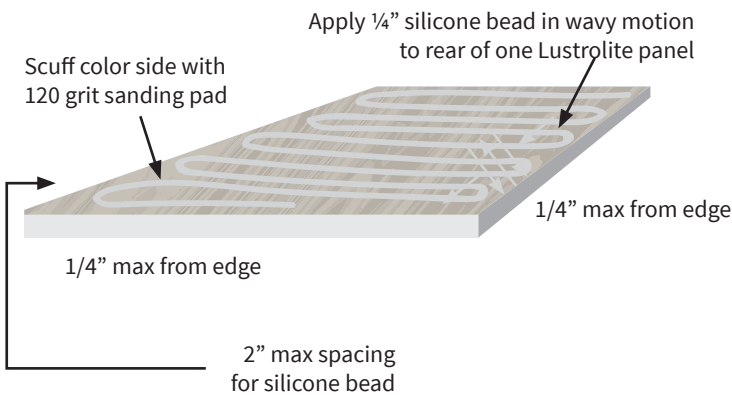

Figure 26: Lustrolite Preparation

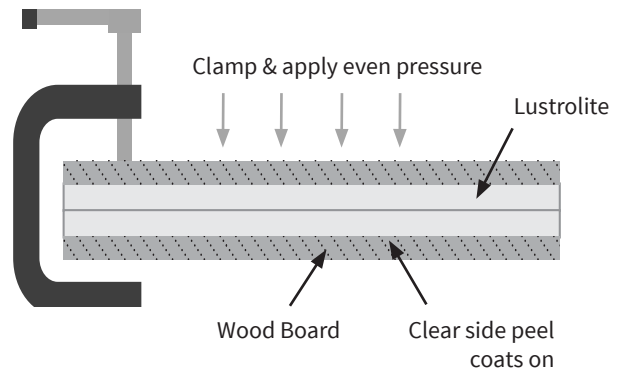

Figure 27: Laminating Lustrolite to Lustrolite

Step 7 – Jointing & Capping Lustrolite with Profiles

Preliminaries

Lustrolite panels can be jointed or finished at open ends using applicable aluminum or PVC profiles.

- Measure and cut profile to length with applicable cutting tool
- Profile should ideally finish flush with the edges of Lustrolite
- Prepare Lustrolite for installation (see section Preparing for Panel Installation for correct procedure)
- If installing Lustrolite in a wet areas, apply silicone to both panel housings in the profile
- If installing Lustrolite in a dry area, apply silicone to the housing accommodating the longest or widest panel only
- Install first Lustrolite panel and maneuver profile and panel into correct position on the wall allowing 2mm for expansion of Lustrolite at the profile.
- Insert second Lustrolite panel allowing for 2mm expansion as previous step
- Continue with installation of additional Lustrolite panels or complete the installation (see section Completing Lustrolite Installation for correct procedure).

The use of profiles generally eliminates visible silicone beads at joints and ends as well as painting the substrate behind joints.

EGR stocks four types of silver anodized aluminum profiles:

- Internal Corner
- External Corner
- Straight Joint
- End Cap

Internal Corner Profile

These profiles can be easily powder coated to match Lustrolite if required.

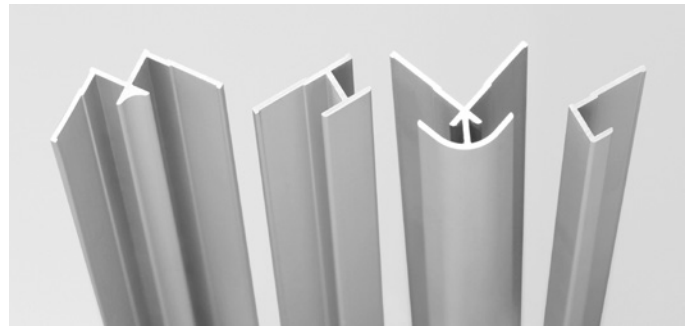

Figure 28: Lustrolite Profile Types

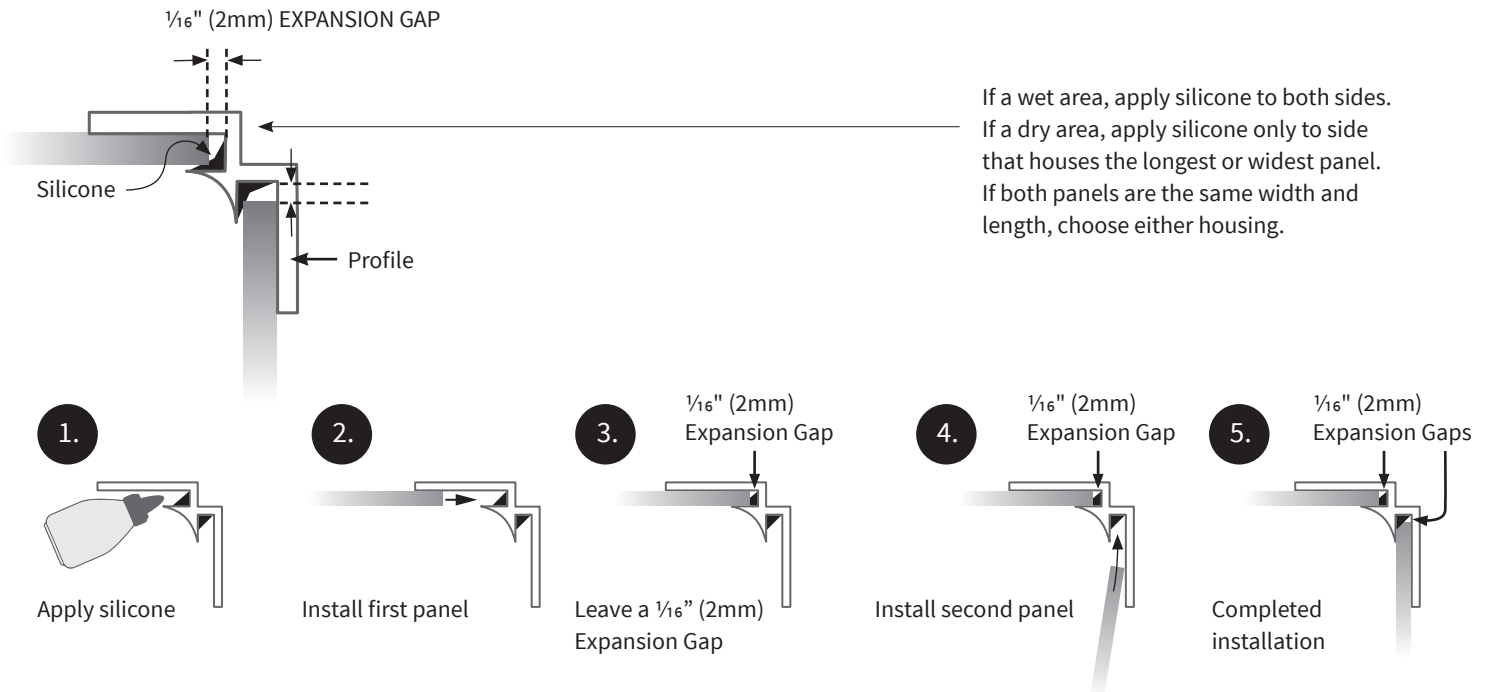

Figure 29: Installation of Internal Corner Profile

External Corner Profile

- a. Measure and cut profile to length with applicable cutting tool
- b. Profile should ideally finish flush with the edges of Lustrolite
- c. Prepare Lustrolite Panels for installation (see section Preparing for Panel Installation for correct procedure)
- d. If installing Lustrolite in a wet areas, apply silicone to both panel housings in the profile
- e. If installing Lustrolite in a dry area, apply silicone to the housing accommodating the longest or widest panel only
- f. Install first Lustrolite panel and maneuver profile and panel into correct position on the wall allowing 2mm for expansion of Lustrolite at the profile.
- g. Insert second Lustrolite panel allowing for 1/16" (2mm) expansion as previous step
- h. Continue with installation of additional Lustrolite panels or complete the installation (see section Completing Lustrolite Installation for correct procedure).

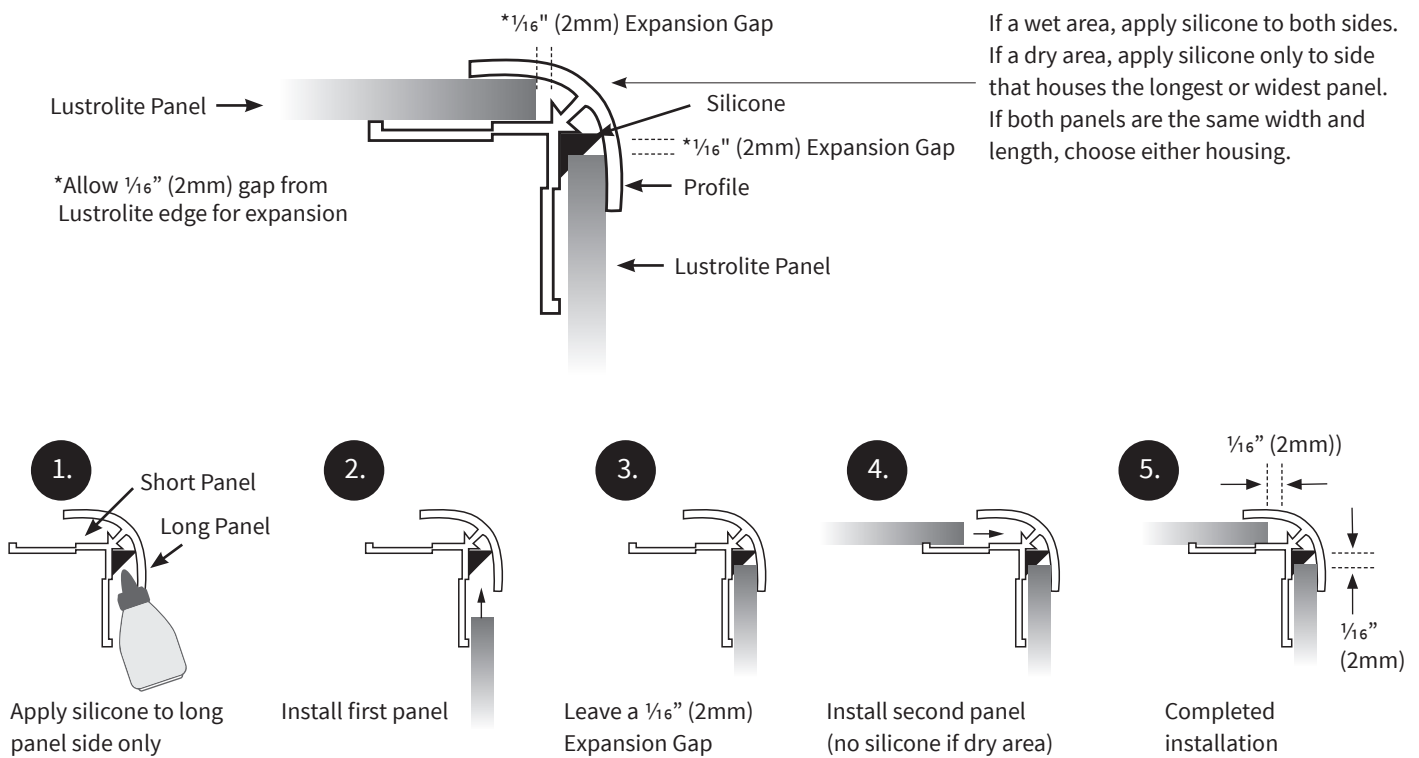
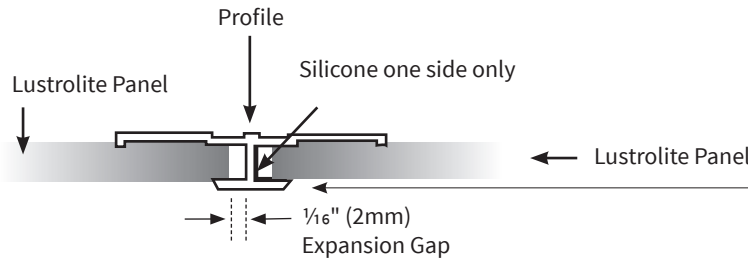

Figure 30: Installation of External Corner Profile

Straight Joint Profile

- a. Measure and cut profile to length with applicable cutting tool
- b. Profile should ideally finish flush with the top and bottom edges of Lustrolite
- c. Prepare Lustrolite Panels for installation (see section Preparing for Panel Installation for correct procedure)
- d. If installing Lustrolite in a wet areas, apply silicone to both panel housings in the profile
- e. If installing Lustrolite in a dry area, apply silicone to the housing accommodating the longest or widest panel only
- f. Install first Lustrolite panel and maneuver profile and panel into correct position on the wall allowing 2mm for expansion of Lustrolite at the profile.
- g. Insert second Lustrolite panel allowing for 1/16" (2mm) expansion as previous step
- h. Continue with installation of additional Lustrolite panels or complete the installation (see section Completing Lustrolite Installation for correct procedure).



If a wet area, apply silicone to both sides.
 If a dry area, apply silicone only to side that houses the longest or widest panel.
 If both panels are the same width and length, choose either housing.

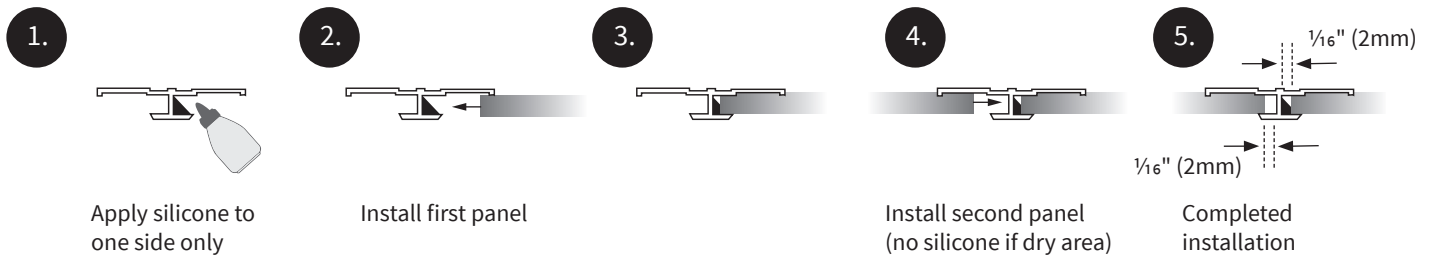

Figure 31: Installation of Internal Corner Profile

End Cap Profile

Preliminaries

The most common use of the End Cap is to provide a neat cap to the edge of Lustrolite often where the panel does not terminate at another wall or fixture.

The End Cap can also be used to fully cap all or more than one Lustrolite edge effectively creating a border feature.

If no joins in caps are required, follow Step A and Step C

If joins are required, follow Step B and Step C

Step A - No Join

- Profile should ideally finish flush with the top and bottom edges of Lustrolite
- Measure and square cut profile to length with applicable cutting tool

Step B - End Cap Corner Joints

Two different methods are recommended for junctions of End Caps at corners.

Miter Join

- Measure caps ensuring a minimum 1/16" (2mm) expansion gap is allowed for between Lustrolite and the internal cap housing
- Cut caps at 45° using an applicable cutting tool such as miter saw with fine tooth aluminum cutting blade for best result

Notched Join

- Measure caps ensuring a minimum 1/16" (2mm) expansion gap is allow for between Lustrolite and the internal cap housing
- Measure and carefully remove the back section of one End Cap at joins using applicable tool such as tin snip.

Step C – Installing Lustrolite & Caps

- Prepare Lustrolite Panels for installation (see section Preparing for Panel Installation for correct procedure)
- Apply silicone to all profile housings including open ends in the Notched Join if used
- Install Lustrolite panel and maneuver profile/s and panel into correct position on the wall allowing 1/16" (2mm) for expansion of Lustrolite at the profile/s

MITER JOINTS

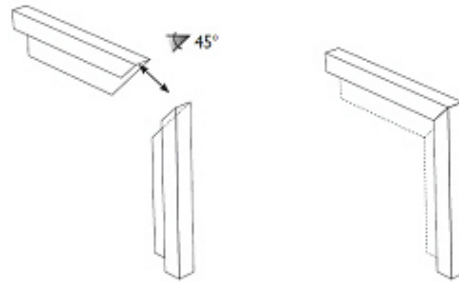

NOTCHED JOINTS

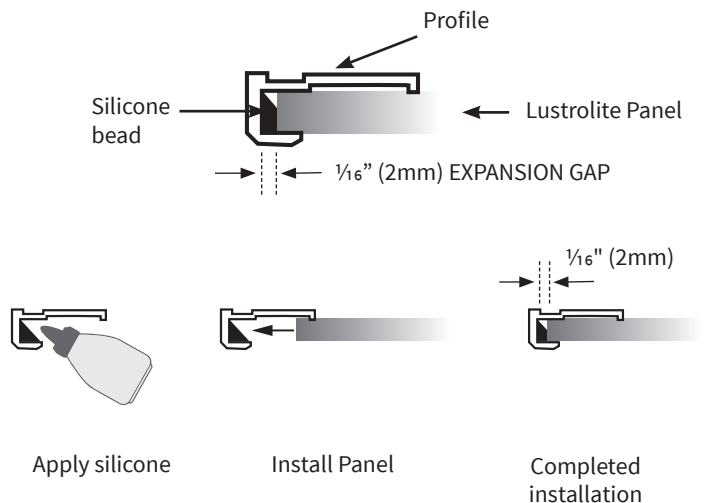
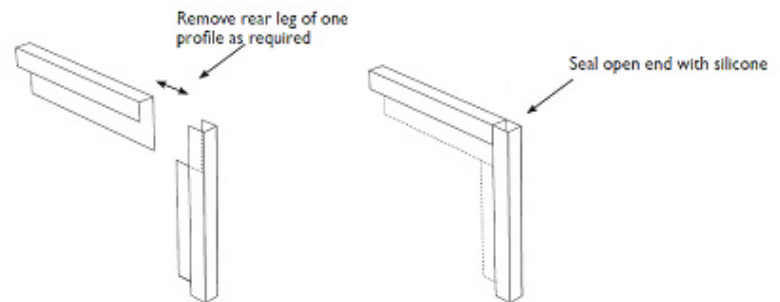

Figure 32: Perimeter Corner Joints

Cleaning & Maintenance

VuPlex is an excellent everyday polish for use with Lustrolite and is highly recommended by EGR. It can be simply sprayed on and wiped down with a clean, dry microfiber cloth. Visit vuplex.co for more information.

Lustrolite can also be cleaned using a soft microfiber cloth or chamois dampened with warm soapy water. Harsh chemicals are generally not required.

More stubborn stains and marks can be removed using the following chemical substances:

- Kerosene
- Bleach
- Mineral Spirits
- 10% Citric Acid solution
- Lemon Juice
- Vinegar
- Liquid Soap
- Glass Cleaner

Lustrolite should not be exposed to the following substances:

- Acetone
- Methylated Spirits
- Abrasive Cleaners
- Aggressive Solvents such as Toluene



EGR preferred polish and protectant for Lustrolite

Warranty

Lustrolite comes with a limited 10 year pro-rated indoor warranty. For further information, please refer to the Lustrolite Warranty Statement at lustrolite.com or contact EGR Building Products info@lustrolite.com / 909 295 6622.

Commercial & Residential Walls

Preliminaries

- Ensure all walls are smooth, clean, dry and plumb
- Ensure the area is free of dust
- Ensure all wall panel fixings are set flush or recessed
- Ensure sufficient lighting and adequate power supply
- Ensure adequate ventilation exists in the installation and work area

This procedure assumes silicone beads will be used at panel joints, corners and edges.

If Joint and Edge Profiles are being used, install accordingly as Lustrolite panels are installed. (See section Installing Profiles for correct installation)

Layout & Joint Preparation

- Assess installation area and determine layout of Lustrolite on walls
- Mark center of all panel joints on walls ensuring 5/32" (4mm) expansion gaps are allowed for

- At openings or fixtures use a joint if more than 1/3 the width or length of the panel has to be removed to fit around the opening or fixture
- Paint panel joints and junctions at walls and other surfaces with color matching paint and allow to dry

Preparing & Installing Lustrolite

- Cut Lustrolite to size (See section Sizing & Cutting Lustrolite for correct procedure)
- Drill holes for all applicable penetrations (See section Drilling Lustrolite for correct procedure)
- Finish Lustrolite edges as required (See section Edge Finishing for correct procedure)
- Prepare Lustrolite rear surfaces for installation (See section Preparing for Lustrolite Installation for correct procedure)
- Install Lustrolite panels (See section Completing Lustrolite Installation for correct procedure)

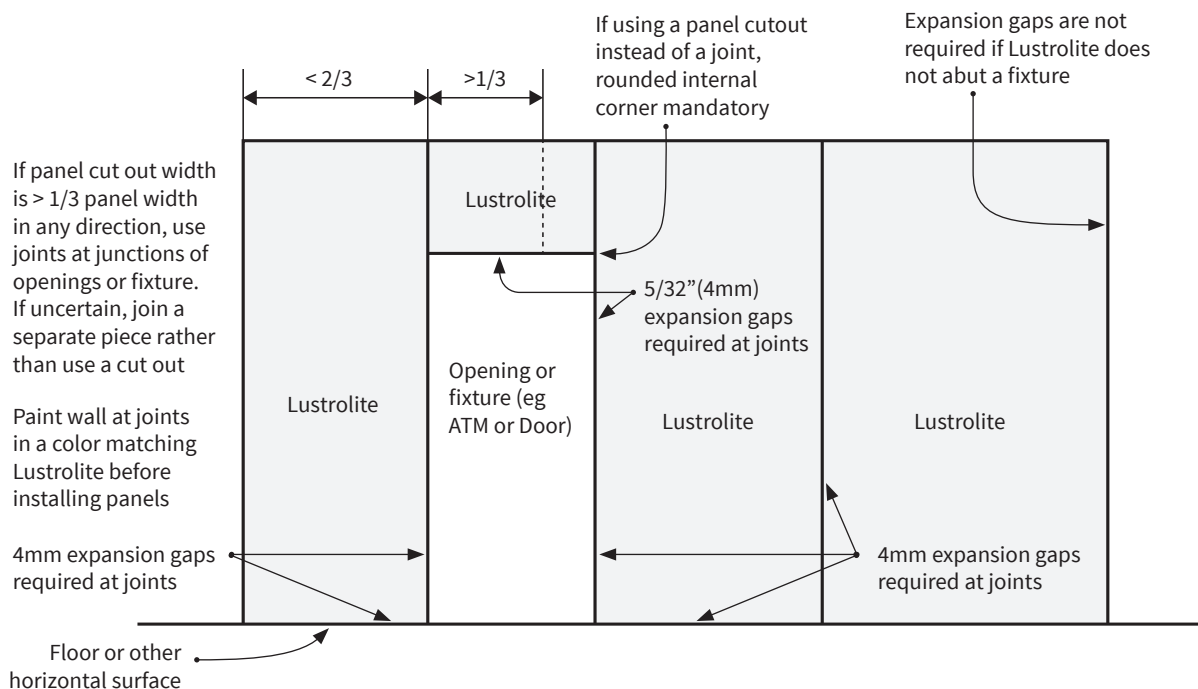

Figure 33: Lustrolite Panel Layout Example

Restroom Doors & Partitions

Preliminaries

- Ensure installation area is free of dust
- Ensure sufficient lighting and adequate power supply
- Ensure adequate ventilation exists in the work area

This application assumes Lustrolite will be applied to side edges (not top and bottom) and front and rear faces of wooden doors and partitions.

The application does not require expansion joints where Lustrolite contacts each other at surfaces and edges due to the use of PUR adhesive.

Cut Substrates to Size

- Measure and cut door and partition substrates to correct sizes. Widths should be $5/16"$ (8mm) less than finished sizes.
- Prepare wood substrate edges and faces for lamination (See section on Laminating Lustrolite for correct procedure)
- Determine Lustrolite edge treatment (See section Edge Finishing). The recommended finish is butt join with square edge finish.

Cut Lustrolite to Size

- For edges, cut Lustrolite strips of slightly wider (eg 1mm) than width of the door or partition thickness.
- Lustrolite faces will cover the ends of each strip. Cut Lustrolite to suit the door or partition widths plus at least $11/32"$ (8.5mm) to account for Lustrolite strips adhered to each edge.
- Finish all edges with planer and 120 then 240 grit sanding block. Ensure correct widths are achieved and all sharp edges are removed.

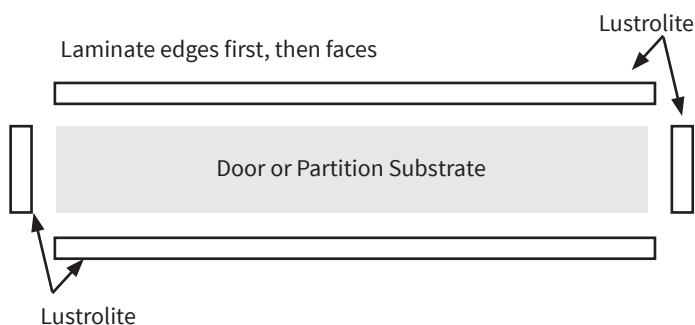
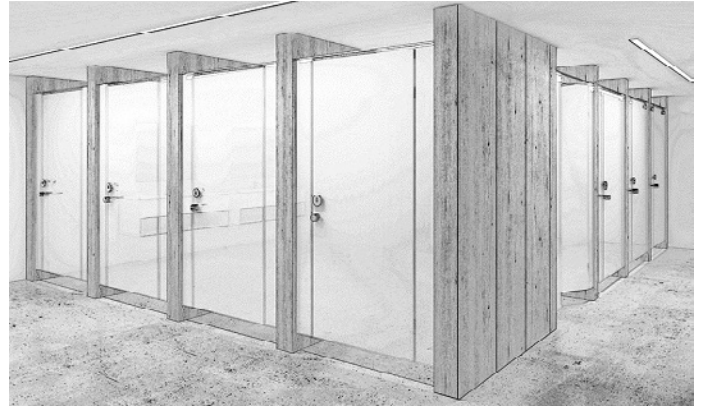

Figure 34: Exploded Plan View of Door or Partition



Laminating Lustrolite to Door & Partition Edges

- More than one door or partition can be produced at once however ensure the quantity can be managed. No more than three to four at a time for one or two installers
- Laminate Lustrolite strips to all edges (See section on Laminating Lustrolite for correct procedure).

Laminating Lustrolite to Door & Partition Faces

- Laminate Lustrolite to all surfaces (See section on Laminating Lustrolite for correct procedure).
- Fill any gaps with clear neutral cure silicone sealant
- Remove peel coats and allow silicone to cure
- Apply VuPlex and wipe down Lustrolite with clean soft microfiber cloth

Hardware Installation

- Drill holes for hinges and lock sets and fit accordingly (see section Drilling Lustrolite for correct procedure).

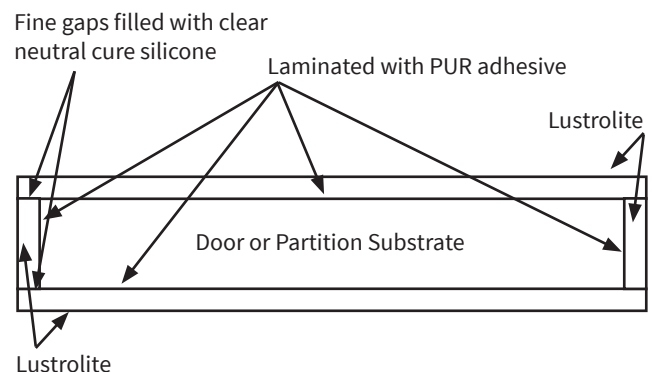

Figure 35: Plan View of Laminated Door or Partition

Standoff Features & Signage

Preliminaries

Lustrolite can be used as a decorative wall feature using applicable standoff clamps.

Spans between standoff clamps and standoff distances from the wall can be increased by laminating Lustrolite panels to each other or other types of substrates.

- Ensure the weight of Lustrolite can be adequately supported by the wall substrate and clamps
- Ensure standoff clamps are fixed into solid structure such as masonry or steel or wood frame behind Lustrolite
- Edge clamps or those which penetrate Lustrolite can be used
- Ensure rubber spacers / grommets are used between Lustrolite and both sides of standoff clamps
- Never over tighten clamps

Cut Lustrolite to Size

- Determine size and shape of Lustrolite
- Cut Lustrolite to size (see section Sizing & Cutting Lustrolite for correct procedure)

Drilling Lustrolite

Drilling is generally only required if penetrating standoff clamps are used

- Determine position of clamps using the figures in this section as a guide.
- Drill holes for clamps (see section Drilling Lustrolite for correct procedure).

Wall Preparation

- Mark on wall center points of standoff clamp fasteners. Use Lustrolite as a template by holding against the wall
- Drill applicable holes
- Fasten clamp bases to wall with applicable fasteners
- Position Lustrolite over or inside clamp bases
- Tighten clamps until Lustrolite is held firmly in place



Figure 36: Penetrating Standoff Clamps



Figure 37: Edge Standoff Clamps

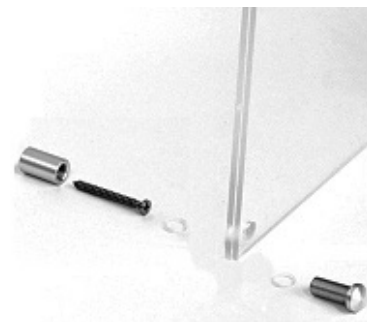

Figure 38: Lustrolite with Standoff Clamp Exploded View

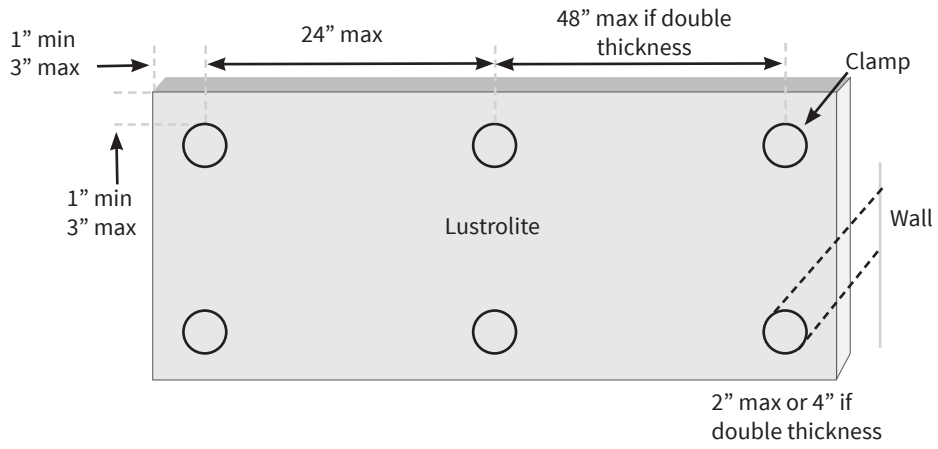

Figure 39: Penetrating Standoff Clam Layout

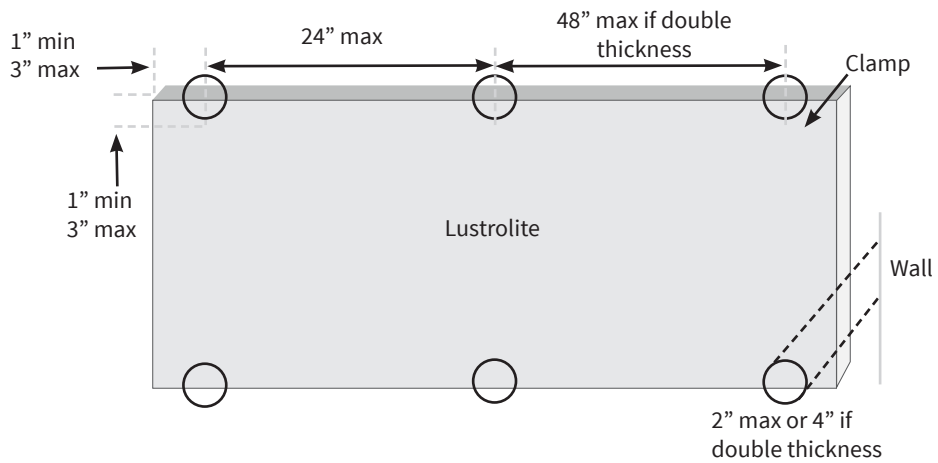

Figure 40: Edge Standoff Layout

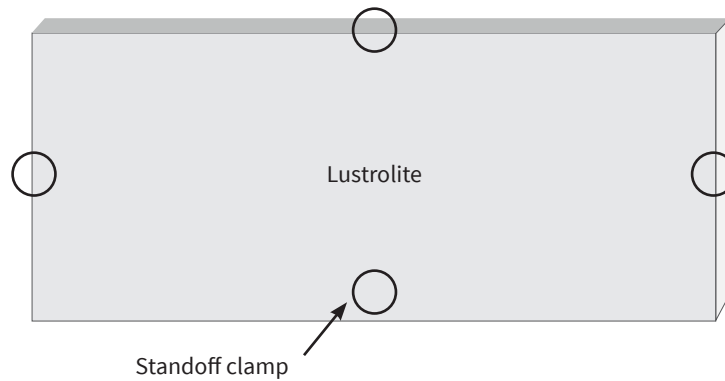

Figure 41: Incorrect Layout

Cabinet Doors

Preliminaries

Lustrolite can be used in conjunction with various substrates to produce beautiful glass-like faced cabinet doors.

Lustrolite is often used with two different substrates to make cabinet doors; aluminum frame or wood panel such as MDF.

Type A: Aluminum Frame with Lip

- Assemble aluminum frame ensuring it is square.
- Measure Lustrolite to size so it fits inside the frame ensuring applicable expansion gaps are accounted for

Lustrolite expands and contracts with temperature changes by 0.65mm per 36" of panel for every change in temperature of 18° F

Therefore, if a door is 36" square at room temperature, Lustrolite will expand by 1.3mm in total if the temperature rises by 18° F

To be safe, a gap of 1mm should be allowed between the edge of Lustrolite and the lip on all sides of the door frame where temperatures reach 90° F. Larger gaps should be used if the installation location experiences even higher temperatures.

- Cut Lustrolite to size (see section Sizing & Cutting Lustrolite for correct procedure)
- If Lustrolite has a rear side peel coat, remove it.

¼" silicone bead

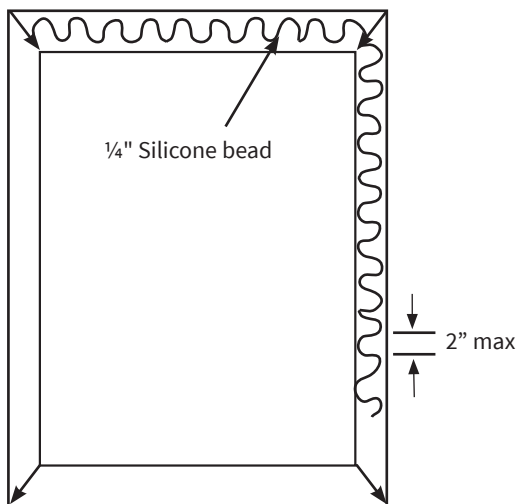

Figure 42: Lustrolite Door Frame

- Place Lustrolite in place on the frame and mark the area that contacts it.
- Using 120 grit sanding pad scuff the color side of Lustrolite that contacts the aluminum frame only. Do not scuff if installing Lustrolite Décor Fusion patterns such as Lavato Oak, Titanium or Calacatta Marble.
- Ensure front of aluminum frame is clean and dry.
- Apply ¼" neutral cure sealant bead in a wavy pattern to the frame.
- Press Lustrolite firmly into the silicone and ensure good contact and adhesion. Remove excess silicone using plastic trowel and microfiber cloth dampened with mineral spirits.
- Maintain light even pressure in horizontal position for 24 hours or until silicone cures.

Type B: Wood Substrate such as MDF

- Laminate Lustrolite to wood faces, not edges. See Step A Laminating Lustrolite to Wood Substrates under the Section Laminating Lustrolite for correct procedure
- Leave all peel coats in place on the face of Lustrolite and apply applicable edge treatment such as 1mm StyleLite edge band via manual means or preferably using an automatic edgebander.

Minimum 1mm expansion gap if using a frame with lip



Figure 43: Lustrolite Door with Aluminum Frame (Expansion Gap)



Figure 44: Lustrolite Aluminum Framed Cabinet Door (Reverse Side)

Shower & Bath Walls

Preliminaries

Lustrolite can be installed in the shower and above or around bath tubs.

This procedure assumes silicone beads will be used at panel joints, corners and edges.

- Ensure installation area is free of dust
- Ensure all walls are smooth, clean, dry and plumb if applicable
- Ensure all substrate wall panel fixings are set flush or recessed
- Ensure all plumbing, pipes and penetrations allow for thickness of Lustrolite
- Ensure applicable waterproofing precautions behind Lustrolite have been taken
- If Joint and Edge Profiles are being used, install accordingly as Lustrolite panels are installed. (See section Installing Profiles for correct procedure)

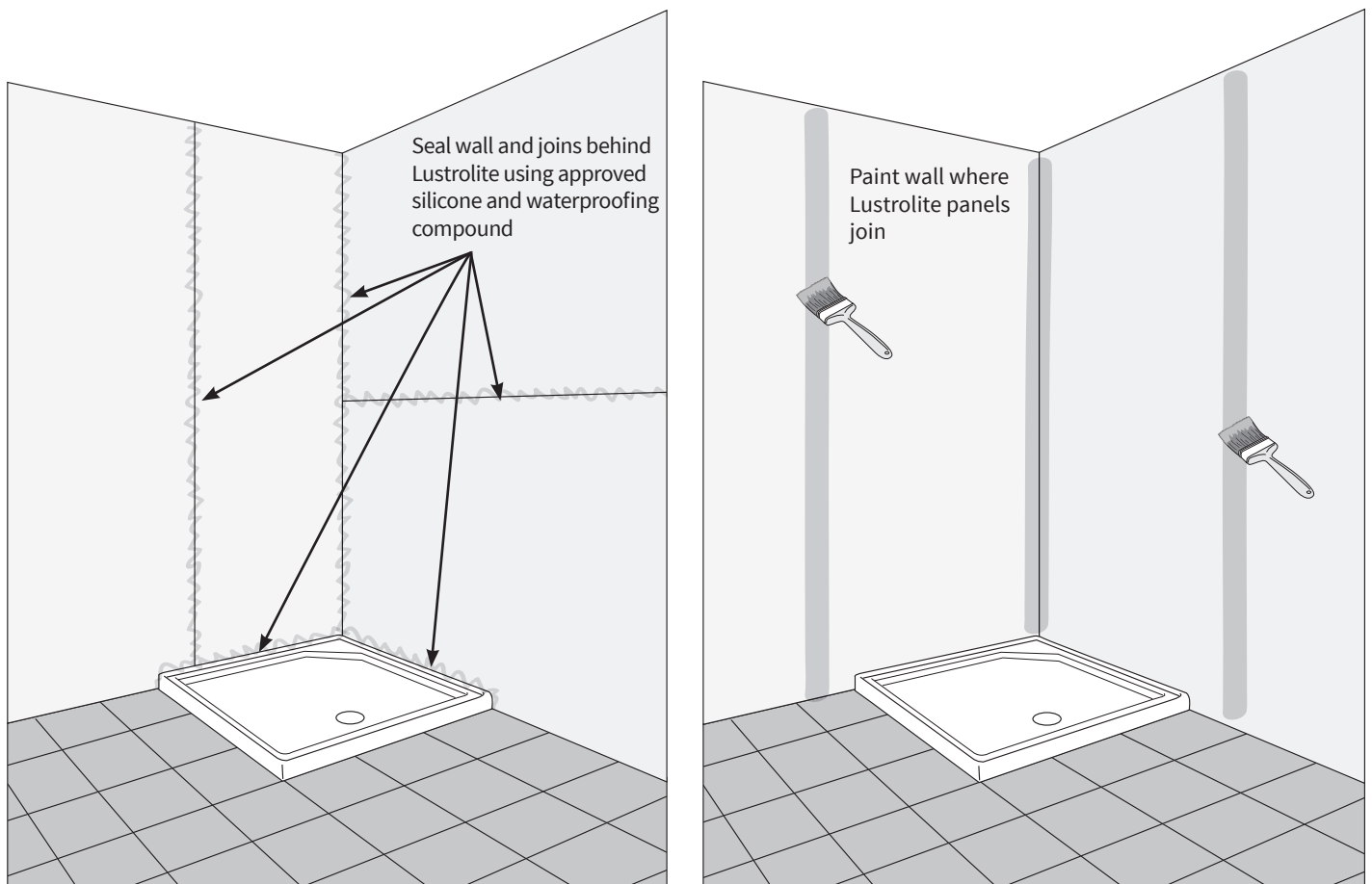

Figure 45: Lustrolite Panel Layout in Shower

Layout & Joint Preparation

- Assess installation area and determine panel layout on walls
- Mark center of all panel joints on walls ensuring 5/32" (4mm) expansion gaps are allowed for
- At openings or fixtures use a joint if more than 1/3" the width or length of the panel has to be removed to fit around the opening or fixture
- Paint wall at joints and corners with color matching paint and allow to dry (not required if profiles are used)

Preparing & Installing Lustrolite

- Cut Lustrolite to size (See section Sizing & Cutting Lustrolite for correct procedure)
- Drill holes for all applicable penetrations (See section Drilling Lustrolite for correct procedure)
- Finish exposed Lustrolite edges as required (See section Edge Finishing for correct procedure).
- Prepare Lustrolite rear surfaces for installation (See section Preparing for Lustrolite Installation for correct procedure)
- Install Lustrolite panels (See section Completing Lustrolite Installation for correct procedure).

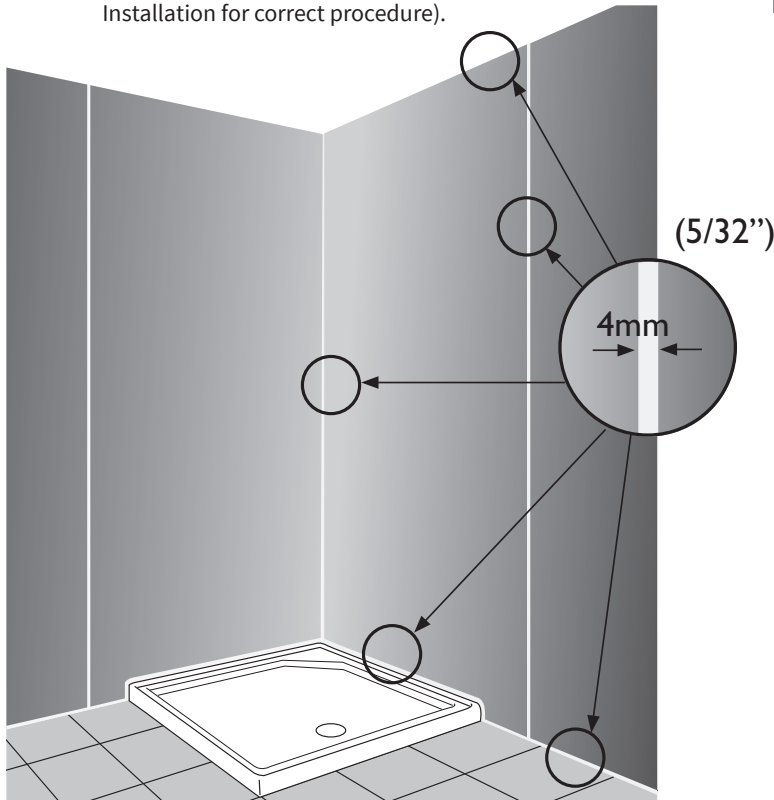

Figure 46: Expansion Gaps

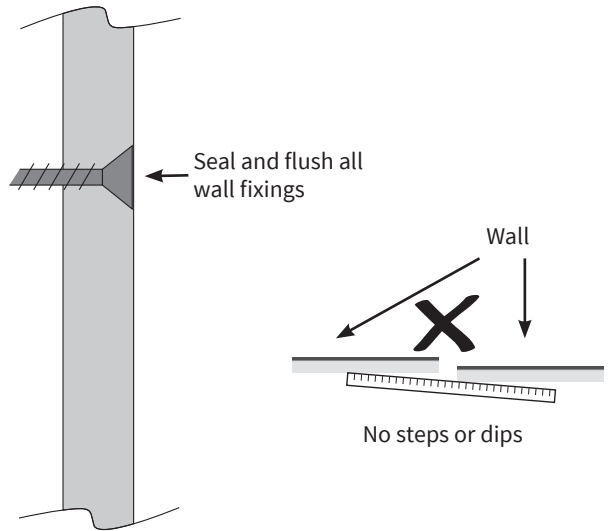

Figure 47: Wall Preparation

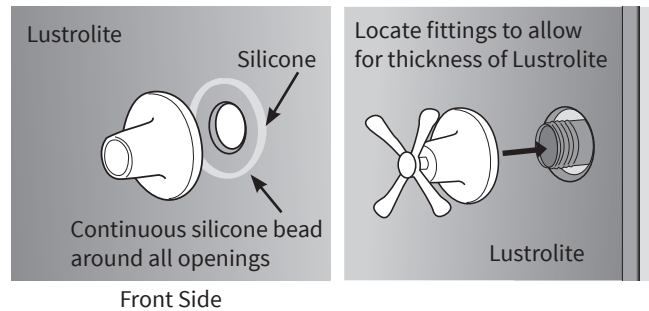

Figure 48: Penetration Preparation

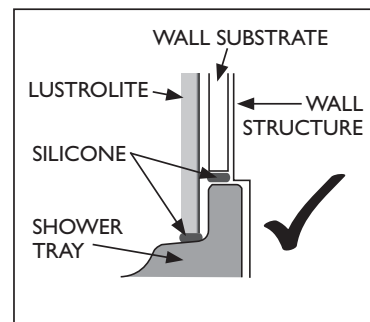

Figure 49: Shower Tray Detail

Backsplashes

Preliminaries

Lustrolite can be installed as a backsplash in kitchens, laundries and bathrooms.

In the kitchen, Lustrolite can be used as a backsplash directly behind electric and induction cooktops and stoves under strict conditions; however safest use is away from heat sources.

Importantly, do not allow hot cookware or boiling liquids to contact Lustrolite

For Backsplash Behind Cooktop or Stove

Layout & Joint Preparation

- Assess installation area and determine panel layout on walls
- If applicable, mark centers of joints on walls ensuring $5/32"$ (4mm) expansion gaps are allowed for
- At openings or fixtures use a joint if more than $1/3"$ the width or length of the panel has to be removed to fit around the opening or fixture
- Paint wall at joints and corners with color matching paint and allow to dry

Preparing & Installing Lustrolite

- Cut Lustrolite to size (See section Sizing & Cutting Lustrolite for correct procedure)
- Drill holes for all applicable penetrations (See section Drilling Lustrolite for correct procedure)
- Finish exposed Lustrolite edges as required (See section Edge Finishing for correct procedure)
- Prepare rear surfaces of Lustrolite as shown in Figure xx (Also see section Preparing for Lustrolite Installation)
- Install Lustrolite panels (See section Completing Lustrolite Installation for correct procedure)

For Backsplash & Similar Applications not Behind Heat Producing Appliances

- The process is the same except that extensive application (multiple beads) of silicone behind the heat source is not required

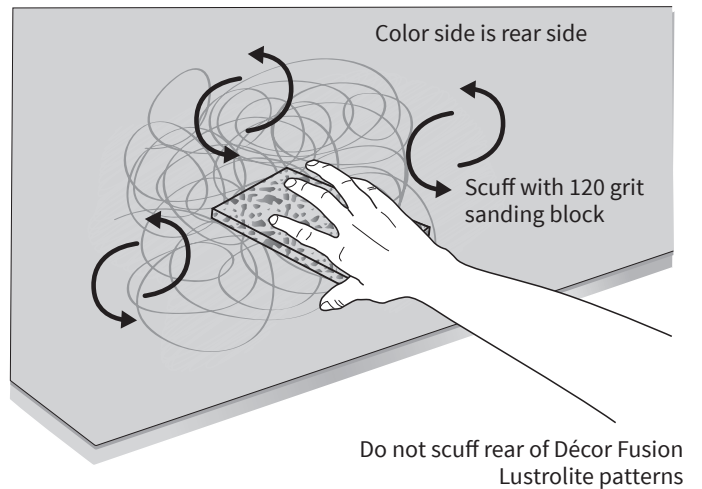

Figure 50: Rear Side Preparation

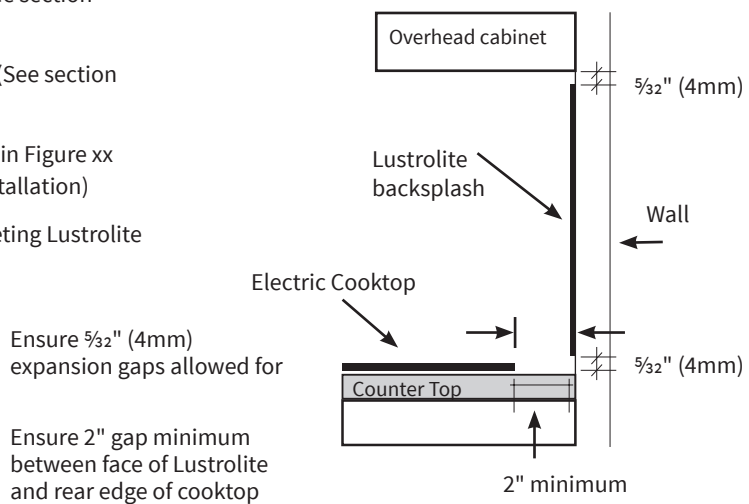

Figure 51: Backsplash Elevation

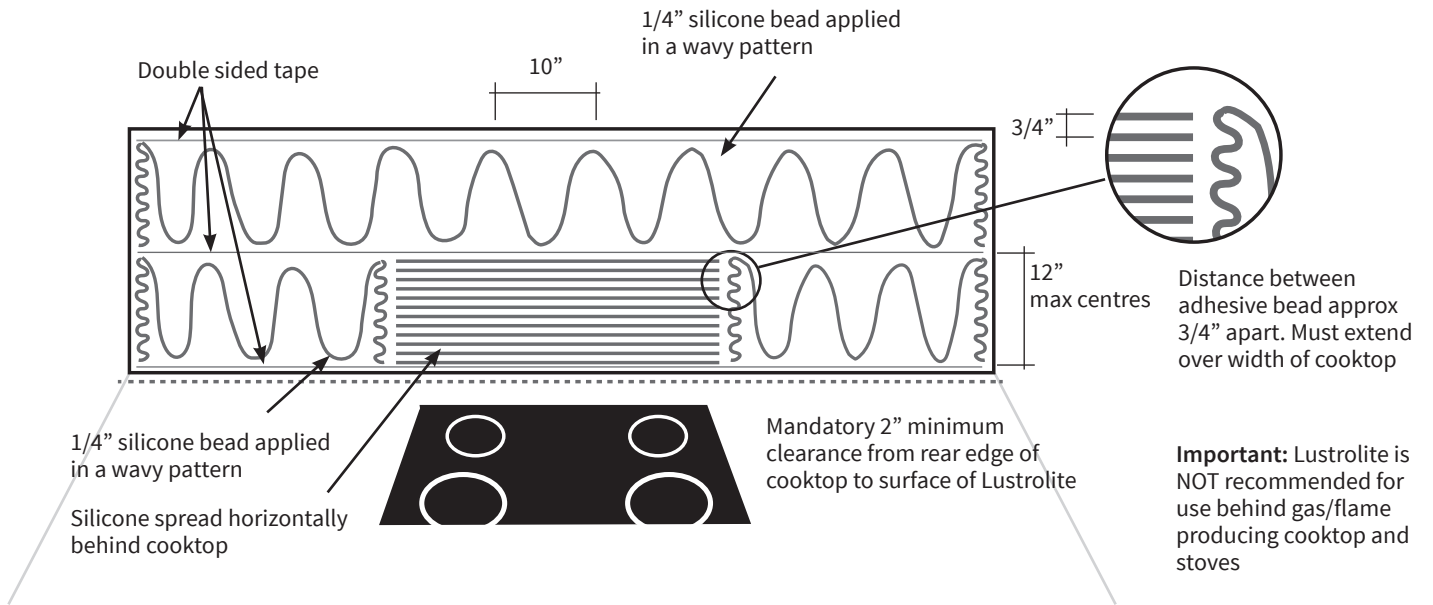

Figure 52: Reverse side of Lustrolite for Backsplash Installation Behind Electric Cooktop

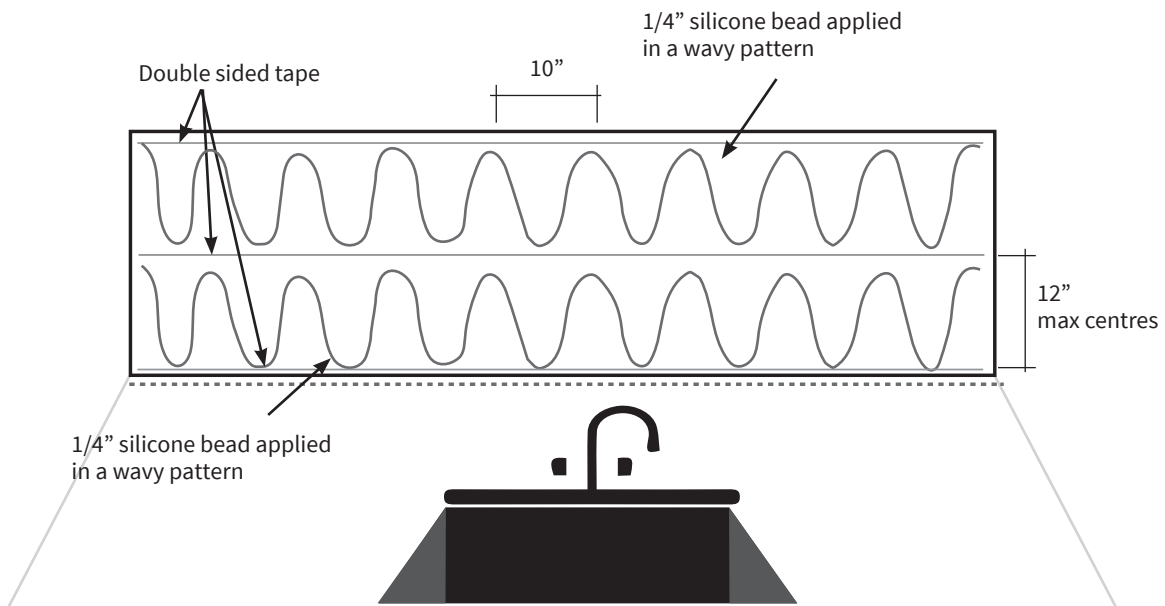

Figure 53: Reverse side of Lustrolite for Backsplash Installation (No Heat Source)

 **Lustrolite**[®]

 **Lustrolite 100**[®]

EGR Building Products Representatives

National

Lindon Flancbaum
909 744 4977
lflancba@egrusa.com

East Coast & Canada

Juan Rubio
909 732 0313
jrubio@egrusa.com

Mid West

Jeffrey Johnson
909 815 0431
jejohnso@egrusa.com

lustrolite.com

243-20818 GB V3 211118 Ingrid

EGR
DECOR